

# Low Frequency Velocity Transducer System

## Datasheet

Cordant™

185M2670 Rev. A

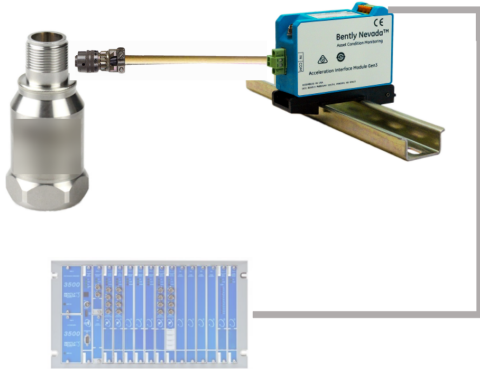

## Description

The **Low Frequency Velocity Transducer System (LFVTS)** is specifically designed for low frequency and low amplitude vibration measurements from machines, such as hydroelectric turbines where slow rotating speeds require detecting low vibration signals. It detects the vibration of the stator core, stator frame, and bearing housing supports. The LFVTS is designed to provide early warning of pending machinery problems and to help in diagnosing problems before they become serious.

Stator core and stator frame vibration can cause fretting and damage to the winding insulation. To detect these problems before serious damage occurs, mount the low frequency accelerometer on the outer diameter of the stator core and frame.

Bearing housing vibration can distort levels of vibration measured by shaft-observing proximity probes. To detect premature failure of machine components and prevent significant machine problems, place the LFVTS in locations that measure both shaft-relative and bearing-absolute vibration signals. The low frequency accelerometers can be mounted to the bearing housing either as a stand-alone measurement or in the same orientation as existing proximity sensors.

The LFVTS comprises three components: (1) 350620 Low Frequency Positive Accelerometer Interface Integration Module (LF+AIIM), (2) Interconnection Cable, and (3) Low Frequency (LF) Accelerometer (see [Figure 1: LFVTS on page 12](#)).

The **350620 LF+AIIM** provides an accurate analog signal processing and conditioning of an electrical equivalent acceleration vibration signal from a LF accelerometer within a rotating machine. The LF+AIIM also integrates the



acceleration signal into the velocity vibration signal directly proportional in amplitude to the equivalent mechanical velocity vibration magnitude (of the input signal). The velocity output signal can be applied to appropriate monitoring equipment for display of velocity vibration magnitude and for detecting alarm conditions.

The **Interconnection Cable** is generally a shield twisted-pair-conductor cable with 2-pin female connector at one end and blunt cut at the other end. Different options of interconnection cables are listed in [Interconnection Cables on page 6](#).

The **Low Frequency Accelerometer** measures absolute (relative to free space) bearing housing, casing, or structural vibration. The sensor is a shear-mode piezoelectric based accelerometer that incorporates embedded integrated electronics in a solid-state design. There is no moving part in the sensor that potentially would induce mechanical degradation and fatigue of components. The sensor can be mounted at any angle of orientation. There are two options of the Low Frequency Accelerometers: the BN 185M3314's sensitivity is 500 mV/g; the BN 185M3313's is 1,000 mV/g. Their other performance specifications are slightly different (refer to the [LF Accelerometer Specifications on page 9](#)).

The Low Frequency Velocity Vibration Transducer System (with only BN 185M3313 and 185M3314 LF Accelerometers) is compatible with the Bently Nevada™ 3500/46M with the Multimode Positive Input I/O Module (169715-xx) or the 143729-xx I/O MOD 162776-01 (MOD 3500/4X w Positive Voltage Inputs). These I/O modules enable the monitor to provide positive voltage supply to power up and receive positive signal from the 350620 LF+AIIM. The LFVTS requires a shielded triad (or 3-conductor) cable to connect to the BN 3500 monitor.

## LFVTS Specifications

Parameters are specified from +20 to +30°C (+68 to +86°F) and 100 Hz unless otherwise indicated.

### Electrical (LFVTS)

#### Power Supply Requirements

Supply Voltage Range	+24.0±2.0 VDC
Supply Current Range	15.0 mA nominal, 18.0 mA max.

#### Performances

Output Impedance	50±3 Ω
Sensitivity	<p><b>With BN 185M3314, 500 mV/g acceleration input:</b>          500 mV/in/s (19.68 mV/mm/s) ±8% @ 20°C (68°F), referenced to 61.445 Hz</p> <p><b>With BN 185M3313, 1,000 mV/g acceleration input:</b>          1,000 mV/in/s (39.37 mV/mm/s) ±8% @ 20°C (68°F), referenced to 61.445 Hz</p>
Dynamic Range	<p><b>With BN 185M3314, 500 mV/g acceleration input:</b> ≤ 10 in/s (See <a href="#">Figure 2: Vibration Nomograph LFVTS on page 13</a>)</p> <p><b>With BN 185M3313, 1,000 [mV/g] acceleration input:</b> ≤ 5 in/s (See <a href="#">Figure 2: Vibration Nomograph LFVTS on page 13</a>)</p>

Electrical Noise	3 mV <sub>RMS</sub> typical (3 ~ 20M Hz, without vibration signal input)
Frequency Response (±3 dB)	<p><b>With BN 185M3314:</b> 0.5 to 2,500 Hz, typical @ 20°C (68°F), referenced to 61.445 Hz</p> <p><b>With BN 185M3313:</b> 0.7 to 2,500 Hz, Typical @ 20°C (68°F), referenced to 61.445 Hz</p>
Temperature Sensitivity Change	±18% -40°C to 85°C (over specified temperature, referenced @ 20°C and @ 61.445 Hz sensitivity)
Amplitude Non-Linearity	±3% of full-scale range
Maximum Cable Capacitance Load	200 nf without signal degradation
Load Resistance	≥ 10 kΩ
Output Signal DC Bias Voltage	+10.0±0.15 VDC

### Environmental (LFVTS)

Operating Temperature Range	-40°C to +85°C (-40°F to +185°F)
Storage Temperature Range	-40°C to +125°C (-40°F to +215°F)
Shock Survivability	≥981 m/s <sup>2</sup> (1000 g-peak), any direction
Relative Humidity	80%

## LF+AIIM Specifications



### Description

The system is powered by positive voltage power supply and designed for ICP/IEPE (constant current) powered accelerometer.

The LF+AIIM performs the following functions:

- Provides the positive excitation voltage and the constant-current drive for the (ICP or IEPE) accelerometer.
- Generates the proper DC bias level for the output signal.
- Provides frequency filtering with a 3-pole high-pass and 2-pole low-pass filters in passband between 0.5 Hz and 3.2 kHz.
- Integrates acceleration signals to velocity signals.
- Provides a low output impedance amplifier that enables large capacitive loads (long cables) to be driven.
- RoHS compliant.

### Electrical (LF+AIIM)

Parameters are specified from +20 to +30°C (+68 to +86°F) and 100 Hz unless otherwise indicated.

### Power Supply Requirements

Supply Voltage Range	+24.0±2.0 VDC
Supply Current Range	12.0 mA nominal, 15.0 mA max.

### Power to Sensor

IEPE Excitation Voltage	+20.0±2.0 VDC
IEPE Current Range	4±0.3 mA
IEPE Current Range	4±0.4 mA (-40 to +85°C)

### Input Requirements (from Sensor)

Sensor Bias Voltage Range	+7 ~ 13 VDC
Max. Input Signal	5 Vpk at above 61.445 Hz

### Performances (LF+AIIM)

Input Impedance	> 75 kΩ
Output Impedance	50±3 Ω
Converter Gain	1 V/V ±5% @ 61.445 Hz

Sensitivity	<b>With BN 185M3314, 500 mV/g acceleration input:</b> 500 mV/in/s (19.68 mV/mm/s) $\pm 5\%$ @ 20°C (68°F), referenced to 61.445 Hz
	<b>With BN 185M3313, 1,000 mV/g acceleration input:</b> 1,000 mV/in/s (39.37 mV/mm/s) $\pm 5\%$ @ 20°C (68°F), referenced to 61.445 Hz
Dynamic Range	<b>With BN 185M3314, 500 mV/g acceleration input:</b> $\leq 10$ in/s (See <a href="#">Figure 2: Vibration Nomograph LFVTS on page 13</a> )
	<b>With BN 185M3313, 1,000 [mV/g] acceleration input:</b> $\leq 5$ in/s (See <a href="#">Figure 2: Vibration Nomograph LFVTS on page 13</a> )
Electrical Noise	2.3 mV <sub>RMS</sub> typical, (3 ~ 20M Hz, without vibration signal input)
Frequency Response ( $\pm 3$ dB)	0.4 to 3,200 Hz typical @ 20°C (68°F), referenced to 61.445 Hz
Temperature Sensitivity Change	$\pm 15\%$ -40°C to 85°C (over specified temperature, referenced @ 20°C and @ 61.445 Hz sensitivity)
Amplitude Non-Linearity	$\pm 2\%$ of full-scale range
Maximum Cable Capacitance Load	200 nf without signal degradation
Load Resistance	$\geq 10$ k $\Omega$
Output Signal DC Bias Voltage	+10.0 $\pm$ 0.15 VDC

Case Isolation	None (case connected to signal COM)
----------------	-------------------------------------

### Physical (LF+AIIM)

Weight	246 g (8.7 oz)
Sensor Connector	2-conductor Phoenix connector
Power/Signal Connector	3-conductor SpringLoc terminal strip (for AWG 16 to 24)

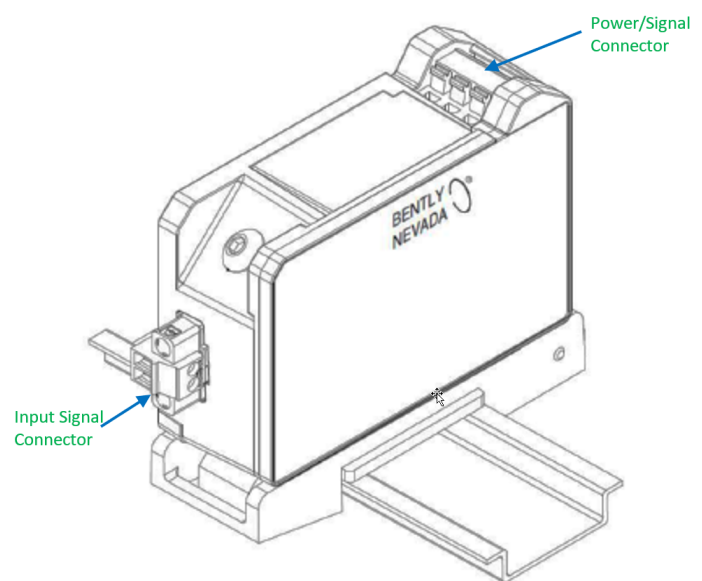

Figure 1: 350620 LF+AIIM with DIN Mount

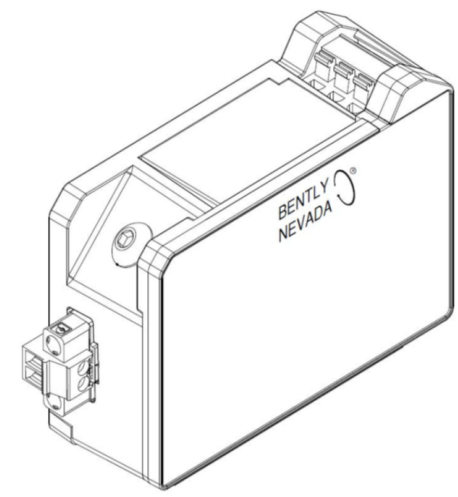

Figure 2: 350620 LF+AIIM with No Mount

## Compliance and Certifications (LF+AIIM)

### FCC

This device complies with part 15 of the FCC Rules. Operation is subject to the following two conditions:

- This device may not cause harmful interference.
- This device must accept any interference received, including interference that may cause undesired operation.

### EMC

EN 61000-6-2

EN 61000-6-4

EMC Directive 2014/30/EU

### RoHS

RoHS Directive 2011/65/EU

## Ordering Information



For the detailed listing of country and product specific approvals, refer to the *Approvals Quick Reference Guide* (108M1756) available from [Bently.com](http://Bently.com).

### 350620 LF+AIIM

#### 350620-AA-BB

#### A: Mounting Option 350620

<b>00</b>	Panel Mount
<b>01</b>	DIN Rail Mount
<b>02</b>	No Mount

#### B: Agency Approval Option

<b>00</b>	Not Required
-----------	--------------

### Accessories

Part Number	Description
134M3057	Adapter
138493-01	DIN Mount
138492-01	Panel Mount

### Interconnection Cables

The following standard cable lengths are available. You can order custom cable lengths in increments of one foot at additional cost. Some cables have a minimum and maximum length. For details, see each part description below.

#### Standard Cable Lengths

Feet	Meters (approximate)
6 ft	1.8 m
8 ft	2.4 m

Feet	Meters (approximate)
10 ft	3.0 m
12 ft	3.6 m
15 ft	4.5 m
17 ft	5.0 m
20 ft	6.0 m
25 ft	7.6 m
30 ft	9.0 m
33 ft	10.0 m
50 ft	15.2 m
99 ft	30.0 m

### Cable Part Numbers

Part number	Description
-------------	-------------

† NOTE: Use 'AA' in the part numbers below to specify the length (in feet) of the cable you want to order.

02173034	<p>Splash-Proof Interconnect Cable</p> <p>Recommended for high electromagnetic noise environment and European Conformance (CE).</p> <p>Shielded 0.382 mm<sup>2</sup> (22 AWG) cable with a splash proof boot over a female connector at the transducer end and flush cut at the monitor end. Temperature range -55 to 125°C (-67 to 257°F).</p>
----------	---

Part number	Description
CB2W100-AAA†	<p>Splash-Proof Interconnect Cable</p> <p>Shielded 0.382 mm<sup>2</sup> (22 AWG) cable with splash proof over molded boot, blunt cut at the monitor end. Temperature range -50 to 200°C (-58 to 392°F).</p> <p>Standard lengths:</p> <p>15 ft (4.5 m)</p> <p>32 ft (9.8 m)</p> <p>64 ft (19.5 m)</p> <p>12 ft (34.1 m)</p> <p>125 ft (38.1 m)</p> <p>150 ft (45.7 m)</p> <p>200 ft (61.09 m)</p>
9571-AA†	<p>Standard Interconnect Cable</p> <p>Shielded 0.382 mm<sup>2</sup> (22 AWG) cable with a moisture resistant female connector at the transducer end and ring lugs at the monitor end. Temperature range -29 to 121°C (-20 to 250°F).</p> <p>Minimum length 2 ft (0.60 m); maximum length 99 ft (30 m).</p>
84661-AA†	<p>Standard Armored Interconnect Cable</p> <p>Stainless steel armor over shielded 0.382 mm<sup>2</sup> (22 AWG) cable with a moisture resistant female connector at the transducer end and ring lugs at the monitor end. Temperature range -29 to 121°C (-20 to 250°F).</p> <p>Minimum length 3 ft (0.91 m); maximum length 96 ft (29 m).</p>

Part number	Description
89477-AA†	<p>Right Angle Interconnect Cable</p> <p>Shielded 0.963 mm<sup>2</sup> (18 AWG) cable with a moisture resistant right angle female connector at the transducer end and ring lugs at the monitor end. Temperature range -29 to 121°C (-20 to 250°F).</p> <p>Minimum length 2 ft (0.6 m); maximum length 99 ft (30 m).</p>
122129-AA†	<p>Short Run Interconnect Cable</p> <p>Shielded 0.963 mm<sup>2</sup> (18 AWG) cable with a moisture resistant female connector at the transducer end and ring lugs at the monitor end. Temperature range -29 to 121°C (-20 to 250°F).</p> <p>Minimum length 6 in (152 mm); maximum length 24 in (610mm).</p>
02173006	<p>0.963 mm<sup>2</sup> (18 AWG) Bulk Cable</p> <p>Shielded twisted pair. Same cable as used on 89477-AA and 122129-AA. Specify number of feet.</p>
02173007	<p>0.382 mm<sup>2</sup> (22 AWG) Bulk Cable</p> <p>Shielded twisted pair. Same cable as used on 9571-AA and 84661-AA. Specify the number of feet. The maximum length that should be used with the transducer is 305 m (1000 ft)</p>

Part number	Description
00502025	<p>Spare Connector</p> <p>Same connector as used on 9571-AA and 84661-AA</p>
101212-01	<p>Right Angle Connector</p> <p>Right angle connector kit. Same connector as used on 89477-AA.</p>

## LF Accelerometer Specifications



### Description

The Low Frequency Accelerometer measures absolute (relative to free space) bearing housing, casing, or structural vibration. The sensor is a shear-mode piezoelectric based accelerometer that incorporates embedded integrated electronics in a solid-state design. There is no moving part in the sensor that potentially would induce mechanical degradation or fatigue of components. The sensor can be mounted at any angle of orientation. There are two options for the Low Frequency Accelerometers: the BN 185M3314 has a sensitivity of 500 mV/g; the BN 185M3313 has a sensitivity of 1,000 mV/g. Their other performance specifications are slightly different.

### Electrical (LF Accelerometer)

Parameters are specified from +20 to +30°C (+68 to +86°F) and 100 Hz unless otherwise indicated.

### Power Supply Requirements (LF Accelerometers 185M3314 and 185M3313)

IEPE Excitation Voltage	+24±6 VDC
IEPE Current Range	2 to 10 mA

### Performances (LF Accelerometer 185M3314 Only)

Output Impedance	400 Ω max.
Output Signal DC Bias Voltage	+8.0±1.0 VDC
Sensitivity (BN 185M3314)	500 mV/g (19.68 mV/m/s <sup>2</sup> ) ±5%
Dynamic Range	10 g Peak
Frequency Response	± 5% 0.3 – 1,200 Hz ± 10% 0.2 – 1,600 Hz ± 3 dB 0.1 – 2,500 Hz
Resonance Frequency	18 kHz
Transverse Sensitivity	≤ 5% of Axial
Vibration Limit	250 g Peak
Shock Limit	5,000 g Peak
Electrical Noise (Equivalent in g)	Spectral 0.1 Hz 15 µg/√Hz 1 Hz 3 µg/√Hz 10 Hz 1 µg/√Hz 100 Hz 1 µg/√Hz
Electromagnetic Sensitivity (Equivalent in g)	150 µg/gauss
Base Strain Sensitivity	0.0005 g/µ-strain max.

Temperature Sensitivity Change	±7% @ -50°C to 120°C
Amplitude Non-Linearity	±1% of full-scale range
Maximum Cable Capacitance Load	20 nf without signal degradation
Load Resistance	≥ 100 kΩ
Case Isolation	Isolated, Internal Shielded
Sealing	Hermetically Sealed

### Performances (LF Accelerometer 185M3313 Only)

Output Impedance	400 Ω max.
Output Signal DC Bias Voltage	+8.0±1.0 VDC
Sensitivity (BN 185M3313)	1,000 mV/g (39.37 mV/m/s <sup>2</sup> ) ±5%
Dynamic Range	5 g Peak
Frequency Response	± 5% 0.6 - 1,200 Hz ± 10% 0.4 - 1,600 Hz ± 3 dB 0.2 - 2,500 Hz
Resonance Frequency	18 kHz
Transverse Sensitivity	≤ 5% of Axial
Vibration Limit	250 g Peak
Shock Limit	5,000 g Peak
Electrical Noise (Equivalent in g)	Spectral 0.1 Hz 15 μg/√Hz 1 Hz 3 μg/√Hz 10 Hz 1 μg/√Hz 100 Hz 1 μg/√Hz

Electromagnetic Sensitivity (Equivalent in g)	150 μg/gauss
Base Strain Sensitivity	0.0005 g/μ-strain max.
Temperature Sensitivity Change	±7% @ -50°C to 120°C
Amplitude Non-Linearity	±1% of full-scale range
Maximum Cable Capacitance Load	20 nf without signal degradation
Load Resistance	≥ 100 kΩ
Case Isolation	Isolated, Internal Shielded
Sealing	Hermetically Sealed

### Physical (BN 185M3314, BN 185M3313)

Weight	205 g (7.23 oz)
Sensor Connector	2-Pin, MIL-C-5015 Style
Case Material	316L Stainless Steel
Mounting	¼-28 Tapped Hole

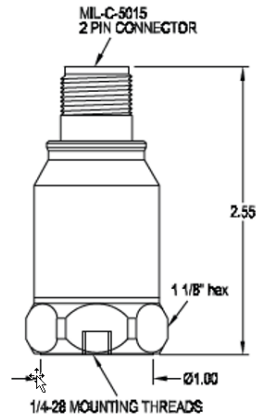

Connections	
Function	Connector pin
power/signal	A
common	B
ground	shell



**Figure 3: LF Accel Mounting**

## Ordering Information

<b>BN 185M3314</b>	500 mV/g
<b>BN 185M3313</b>	1,000 mV/g

## Appendices and Figures

### Required Monitor and I/O Module

<b>BN 3500/46M</b>	Hydro Monitor
<b>169715-01 or -02</b>	Multimode Positive Input I/O Module with Internal or External Terminations
<b>143729 -01 or -02 with MOD 162776-01</b>	I/O Module

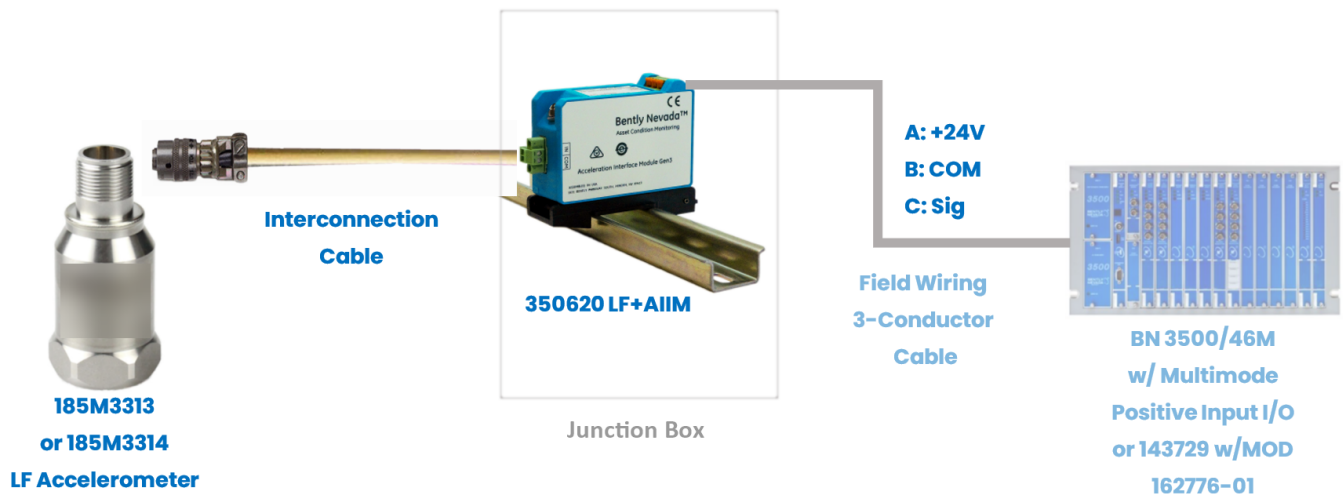

**Figure 1: LFVTS**

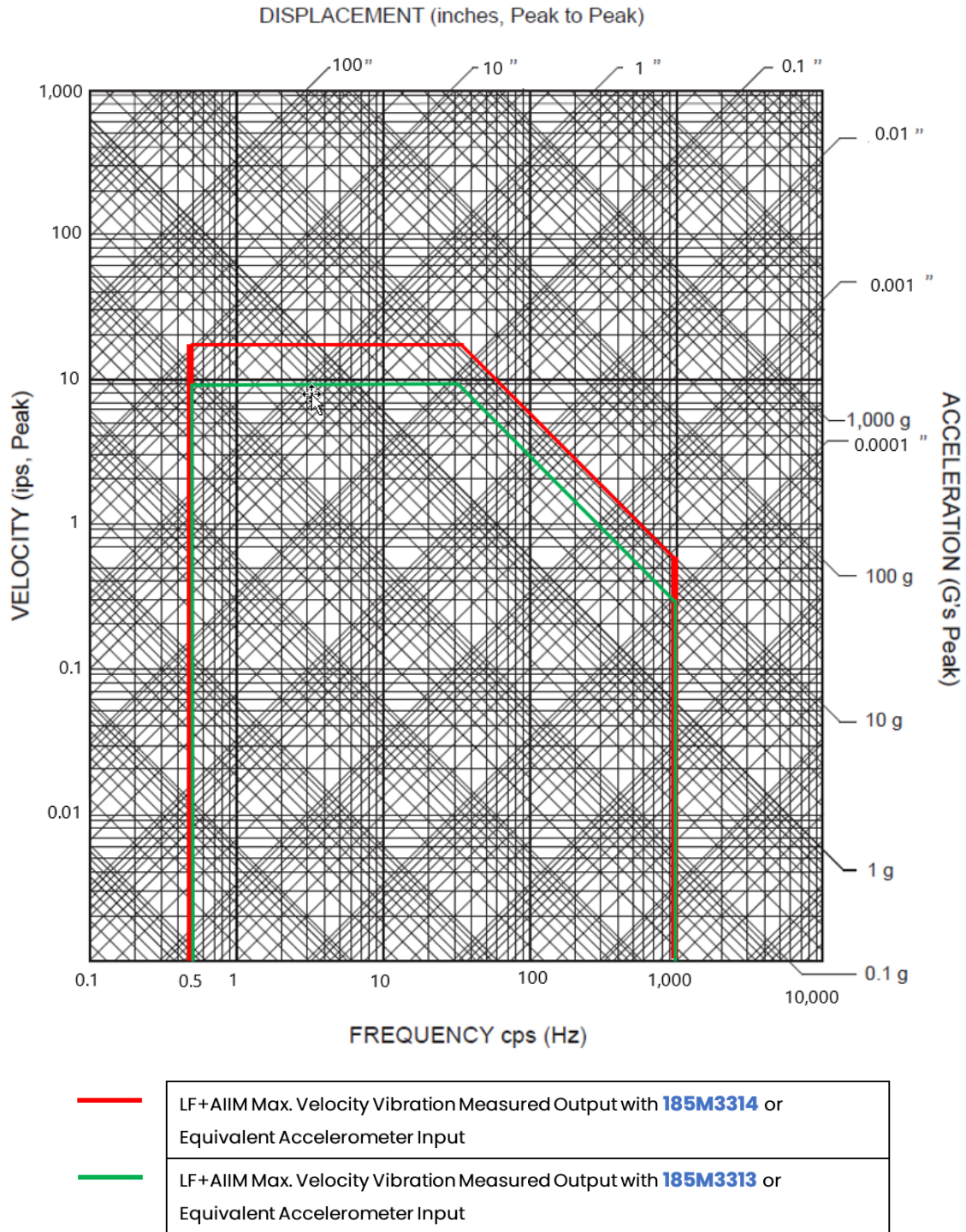

**Figure 2: Vibration Nomograph LFVTS**

---

Copyright 2026 Baker Hughes Company. All rights reserved.

Bently Nevada, a Baker Hughes Company  
1631 Bently Parkway South, Minden, Nevada USA 89423  
<https://bntechsupport.com>